

Llwyn-On Reservoir Scour Valve Refurbishment

J.M.LEWTHWAITE, Technical Director, Blackhall Engineering Ltd.

D.RICHMOND, Site Operations Director, Blackhall Engineering Ltd.

A.R.BEEVER, Senior Project Manager, Blackhall Engineering Ltd.

AK HUGHES, Director of Dams & Water Resources, Atkins Ltd

SYNOPSIS. This paper has been prepared as a case study looking at the refurbishment of critical valves that had previously been declared to be beyond economical repair. It describes the inspection and repair of two 900mm diameter Larner Johnson valves installed some 80 years ago. There were considerable challenges in gaining safe access to enable the valves to be removed from the outlet tunnel and taken back to the factory for refurbishment. Once the valves had been removed the gears and plunger were refurbished, bronze liners were cast and fitted, all iron surfaces were coated with epoxy paint and all bolts were replaced with stainless steel ones. The valves were successfully reinstalled and commissioned.

SITE INFORMATION AND HISTORY

Llwyn-on reservoir is retained by an earth embankment with clay core some 23.85m high and 400m long. It was built between 1910 and 1926 on the Taf Fawr and is the lowest of three dams in the locality. The embankment has a puddle clay core set on a deep concrete filled cut-off trench. The upper part of the slope is protected by powdered pitching 450mm thick whilst the lower slopes are protected by shingling 300mm thick.

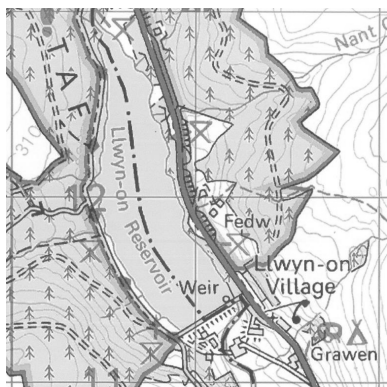

Fig 1: Extract from OS Map



Fig 2: View of tunnel exit and stilling pool

LEWTHWAITE, RICHMOND, BEEVER & HUGHES

fact the owner decided to repair both valves once the condition of the inoperable valve had been seen.

History of Valves at the Dam

The valves have had a mixed and varied history since they were commissioned in 1926.

- During the 1939-45 war the bottom of the valve tower was filled with gravel to minimise possible damage from falling high explosives.
- The chambers were not cleared until 1964 at which point the valves were pronounced inoperable.
- The original manufacturer was consulted and came to the conclusion that there had been a build up of manganese causing the valves to seize. This is now puzzling as no recent signs of manganese have been observed. The treatment was to fill and flush with acetic acid.
- An attempt was made in 1965 to remove one of the valves. The west baffle wall was 90% removed, but the contractor panicked when movement of valve and supporting pipework was thought to have taken place. Studying the site records now it is hard to determine if there had been some movement or a recording error. The uneasiness was compounded as it was thought movement had also taken place in the masonry plug and chamber walls, detected by cracked glass tell tales. The result was that the baffle wall was hastily replaced with concrete and work on the valve abandoned.
- In 1967 the west valve was removed after the gate valves were restrained with large strong back beams complete with timber thrust pads. The beams were let 12 inches into the chamber walls. Any sign of movement was carefully monitored as the valve was removed. Repair work was done to one valve without removing it from the chamber. Some movement was restored to one valve but no steps were taken to prevent further degradation.
- No further action was taken until 1982, although at some unrecorded time attempts were made, no doubt with good intention, to operate the east valve. This was done by the tried and tested method of extending the diameter of the handwheel with levers, resulting in a bent handwheel and, as would be discovered later, broken valve internals.
- An inspection was made and a report written in 1982 and again in 1990 by Welsh Water's designated consultants. Their findings and recommendations were:
 - That according to the manufacturer the original valves were irreparable.
 - The valves should be replaced with butterfly valves.

ENSURING RESERVOIR SAFETY

- The valve chamber was “a congested and inaccessible place”



Fig 4: View of bottom of valve tower

- The recommendation of butterfly valves was based on cost, available chamber space and access. We now believe this would have been a disastrous choice: a quick check of the predicted flow velocity through the system would have shown that it well exceeded the 5 m/s recommended level for a standard butterfly valve.
- No further action was taken until Blackhall’s involvement in 2005.

Acknowledgment is here given to United Utilities who were able to provide much historical information on previous reports, site records and correspondence on these valves.

Valve Type & History

The Larner Johnson valve design originates back to 1910 in the USA. The valves were made exclusively under licence by Blakeborough in the UK for all worldwide markets outside of USA from 1920 until 1989, and thereafter by Blackhall Engineering.

The valve is an inline needle control valve with a very streamlined flow path even at partly open positions. The flow path splits symmetrically around the central controlling plunger, the position of which can be altered to control the annular area forming the valve throat. As the flow merges again after the throat the flow impinges upon itself helping to dissipate energy from the flow.

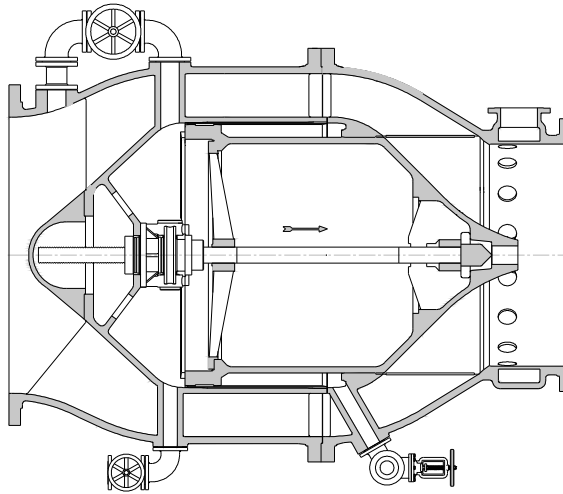

Fig 5: Cross section of a Larner Johnson Valve

The continuous annular throttling cross section at any opening position ensures linear regulation characteristics. These are the key features of the valve that enable it to handle high flow velocities of up to around 12m/s. Operating forces are kept low in service by utilising the available pressure differential to assist in moving the control plunger. Any type of valve operating with high pressure differentials will always be in danger of some cavitation. The fundamental design layout of the Larner Johnson valve easily lends itself to cavitation control where other designs cannot. This is achieved by the addition of an air belt to introduce air into the flow stream immediately after the valve throat, the point of highest flow velocity.

The typical applications for this type of valve are in water handling and treatment installations, anywhere that high pressure differentials result in high velocities. Reservoir and dam scouring and emergency drawdown are classic examples of this. When the discharge is into a tunnel or aqueduct then the controlled and focused jet issuing from a Larner Johnson is ideal. Very early valves were purely pressure operated, however all subsequent designs have some form of mechanical control operating an internal pilot valve. There are many variations of operating mechanisms: worm and wheel, lead screw and nut, lever and linkage, rack and pinion and in this case a double rack and pinion. These operate as “pressure assisted” valves and are inherently safer.

VALVE REFURBISHMENT SCHEME

The problem was quite clear when work began on the reservoir in 1964. There was no effective scour draw down capacity to drop water levels quickly. The west valve was in very poor condition with a limited internal

ENSURING RESERVOIR SAFETY

movement and an excessive seat leakage. The east valve was seized solid and had been since before 1964. The accessibility to the base of the valve tower is very poor and there was a history of rumours of pipework and masonry plug movements when previous attempts had been made to remove the valve.

Blackhall Engineering Investigation

Blackhall Engineering was employed in April 2005 by United Utilities / Welsh Water Authority to inspect and report on the state of the valves. On receiving the enquiry, before even seeing the valves we were able to produce from archive records the manufacturing drawings and an original photograph of one of the original valves as produced in 1923.

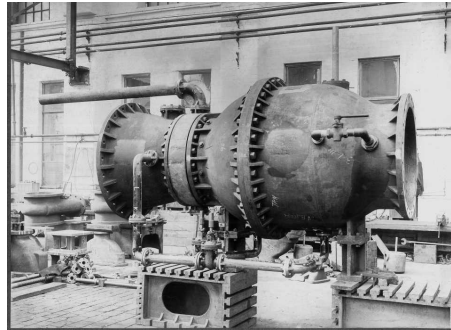

Fig 6: Llwyn-On valve in production.

General assessment of old valves.

The primary task of any investigation is to establish whether the main body castings are capable of being reused, whether the structure is sound.

Deterioration in valve castings can take four forms:

- Mechanical wear, due to movement of internal components, usually repairable.
- Erosion, due to mechanical action by grit or debris.
- Erosion, due to low pressure, high velocity cavitation.
- Corrosion. Can sometimes be combined with erosion to form deep pits and accelerated metal loss.
- Graphitization, where the graphite in the iron castings separates out leading to degradation of the metal properties.

Material Analysis.

One of the most important aspects of assessing the valves was carried out as soon as possible. This involved performing a metallurgical assessment of the base material of the main body castings. Other NDE techniques can also be used, such as Ultrasonic, Radiographic inspections etc.

LEWTHWAITE, RICHMOND, BEEVER & HUGHES

A sample of material was cut from the discharge section casting of the west valve and sent to a laboratory for analysis. The sample was taken from one of the reinforcement ribs between the bolt holes on the flange.

The findings of the laboratory were as follows:

- The casting was of a low strength grey iron with a relatively high carbon equivalent value of 4.5% similar to BS1452 grade 150.
- The casting surface shows some graphitic and general corrosion, down to a maximum depth of 5mm. This is not deemed to be excessive on such a heavy section casting, which would have a corrosion thickness allowance of 16mm added at the design stage.

Internal Examination

The key to the thorough investigation was to prove to be an internal inspection using an endoscopic camera. The findings of this operation were:

- West (Right Hand) Valve.
 - Internal Chamber: The operating mechanisms all appear to be in acceptable condition for an 82 year old valve.
 - Plunger guide: These valves were produced without non-ferrous bearing liners, the cast iron bearing surface was found to be badly corroded and severely pitted. The plunger and pilot valve were found to be capable of achieving full travel.
 - Upstream guard valve: appears to be in good condition.
- East (Left Hand) Valve – Previously over torqued.
 - Internal Chamber: Some damage could be seen to the teeth on both vertical and horizontal racks. The pinion wheel connecting the two racks was missing, the mounting bosses for the pinion shaft on the gear bracket were seen to be sheared off.

Functional tests.

- West Valve.
 - Although the valve achieved full movement the action was found to be far from smooth.
 - There was found to be excessive seat leakage between the 9 and 3 o'clock positions.
 - The plunger was independently lifted in order to achieve better alignment with the valve seat. With the plunger in this position the valve was pressurised. The leakage rate was reduced by 75%.
- East Valve. No functional test could be carried out on this valve due to it being seized, with no means of operating the plunger.

ENSURING RESERVOIR SAFETY

Assessment of Site Access

Measurements were taken to establish the feasibility of removing the valves from the bottom of the valve tower. The only possible option was to remove the valves down the outlet tunnel. A full size mock up was made of the valve from polystyrene flanges mounted on a length of plastic pipe. This was walked through the tunnel to determine whether it would pass all obstructions. It was estimated that the valves could be removed with small localised areas of interference with the tunnel brickwork and outlet pipe intermediate flanges.

Comments on Investigation Findings

West Valve:

- The seat leakage is due to the loss of support and guidance of the plunger afforded by the poor bearing surface condition. The operating mechanism cannot generate sufficient thrust to force the plunger up the seat face to seal.
- There is severe corrosion to valve ancillaries. A cavity has formed behind the discharge section seat ring; this must be repaired before further corrosion exacerbates the situation.

East Valve:

- It was concluded that this valve had stopped functioning and could not be repaired in situ due to the following sequence of events:
 - Infrequent operation, coupled with a poor design of bearing surfaces have caused the valve to seize.
 - The mechanism has been subjected to a very large torque at the handwheel. This has loaded the gear bracket in a tensile direction to a stress beyond its capability and failed. The bracket may have survived a load in a compressive direction.

Recommendations from Initial Investigation

- Remove both valves and conduct a factory refurbishment. The bearings could be brought up to modern standards. The seat leakage eliminated. The valve could be hydraulically tested and re-certified.

Sitework Operational Challenges

Blackhall Engineering were appointed as main contractor to remove and refurbish the East valve in June 2006, and subsequently to perform the task on the West valve in November 2007

The project brought many challenges and difficulties, the most notable of which were:

- Blackhall took responsibility for the Health and Safety on site. This involved managing subcontractors performing a “mixed bag” of site tasks: Hot work, demolition, hazardous chemicals, lifting heavy

LEWTHWAITE, RICHMOND, BEEVER & HUGHES

objects in confined spaces, and the monitoring of possible structural movements. No reportable accidents or near misses occurred during the removal and replacement process.

- The corroded flange bolting was removed by oxy-acetylene burning. The rib stiffeners between the flange bolt holes made the normal operation of grinding through the corroded bolts impossible. The possibility of heat affecting the castings was investigated and a procedure implemented to minimise this.
- The rotten wooden thrust blocks were removed and replaced with epoxy resin. This would ensure a perfectly even pressure being exerted on the bearing area on the side faces of the gate valves. Shuttering was fabricated around the area between the valves and support beams and two pack resin poured into the voids
- Throughout all valve removal operations, any possible movement of the gate valve and pipework was monitored using a micrometer every 15 minutes. No significant movement was detected.
- A free standing lifting frame was built and load tested within the base of the chamber to lift and move the 8000kg valves
- A temporary rail track and supporting steelwork was constructed within the outlet tunnel. This was free standing and did not exert any load on the existing outlet pipe steelwork. The valve was moved on purpose-made bogies along these rails. The rail system was dismantled and moved forward as the valve was moved along the 80m tunnel.
- Some local areas of brickwork within the tunnel walls had to gouged out by around 50mm to allow the valve to pass intermediate flanges along the length of the main dam outlet pipe, such was the tightness of fit of the valve down the tunnel.



Fig 7: Valve on temporary rail system

- The end of the outlet tunnel was beyond the reach of a mobile crane. Therefore the water level in the stilling pond had to be reduced to

ENSURING RESERVOIR SAFETY

allow heavy plant machinery access to carry the removed valve from the end of the outlet tunnel to a position accessible by road transport.

Design Improvements.

The first task on the valves on arriving back in Brighthouse was to perform a hydrostatic pressure test on the body shell. This was to prove the investigation's assessment that the main castings remain sound.

The valves could then be stripped, blast cleaned and prime painted. Significant internal surfaces such as the seat ring and flange faces were re-machined to restore their surfaces. The cavity above the seat ring was repaired using metal filled epoxy repair compound. The main advantage of performing a full factory refurbishment was that the valves could be both restored and brought up to a higher standard than they were originally.

The design improvements made were notably:

- The gear bracket that had fractured was remanufactured from a casting in a superior material. Design changes were also made to improve its strength. FEA was not available in 1923!
- The vertical gear rack was remade in stainless steel.
- Bronze liners were cast and fitted to the bearing surface of the inlet section.



Fig 8: Gear bracket as found.

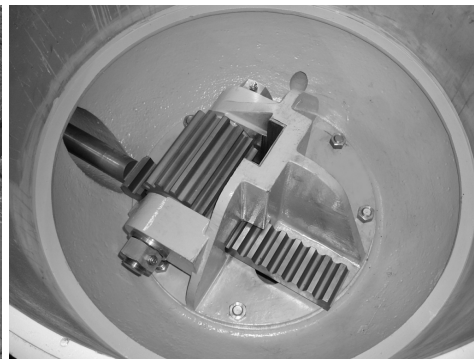

Fig 9: Refurbished gear bracket



Fig 10: Plunger cavity as found.



Fig 11: Refurbished plunger cavity

- The plunger was previously made of cast iron with small strips of bronze providing bearing surfaces. The seized plunger had to be machined out of the inlet body such was the level of corrosion between the two components. A complete new plunger was made from stainless steel casting.
- All iron surfaces were coated in a modern three coat epoxy paint system.



Fig 12: New plunger.



Fig 13: Complete refurbished valve.

- The secondary scour valves were replaced with new valves with longer, more accessible operating spindles.
- All bolting was replaced with stainless steel items.

Significant Project Tasks

- Safe working practices were observed at all times throughout the project.
- The hydrostatic pressure testing of the valve shell at 15bar confirms that the castings remain in a sound and safe condition.

ENSURING RESERVOIR SAFETY

- The hydrostatic seat tests proved the valves were water tight and serviceable.
- The valves were successfully reinstalled and commissioned. A fully open flow test was performed, and the resulting flow rate well exceeded the required draw down rate.



Fig 14: Refurbished valve returning into tunnel.

- The valves were now capable of performing their task safely and reliably for a long period of time, at least another 50 years.

Blackhall Engineering has been able to bring a wealth of unique experience and knowledge to this project, contributing to its successful outcome:

- Experience. The four members of staff directly involved in this project hold a combined 138 years of experience with valves and valve applications.
- Historical Records. We hold all the original drawings and records of every Larner Johnson valve produced in the UK since the 1920's.

These factors enabled Blackhall to accurately analyse the problems associated with faulty valves.

CONCLUSION

Valves that may have previously been written off as being irreparable are not necessarily so. In this case the original manufacturer had deemed these valves beyond repair because they did not have modern inspection equipment to enable them to make a better on site judgement. Without these methods of assessing the valves in situ it was the safer option for both the client and the manufacturer to advise that they be replaced with new. Clients can only make decisions based on the information presented to them. However, with the careful and accurate assessment of the valves whilst in-situ, it becomes possible for the client and contractor to commit to the costs

LEWTHWAITE, RICHMOND, BEEVER & HUGHES

of temporary removal, confident in the knowledge that they are worth the retrieval costs.

Modern manufacturing techniques and materials can positively alter the economic feasibility of repairing old valves, typically half the cost of a new valve. As long as the valve shell is still capable of withstanding the test pressures, it is quite possible to repair and even improve on the original valve specification. One other perceived barrier to valve refurbishment is the cost of site labour. In this case the hours would have had to be spent on removing the valves whether they were going to be repaired or replaced. It is quite tempting for a client to keep costs down by replacing an old valve, designed for the duty, with a new but different type of valve not suited to the application. Any such decision may, however, be a severe compromise to performance and reliability.

In this particular case the Larner Johnson valves were economically repairable, they could be removed safely and they are absolutely the right valve for the job. The Larner Johnson valve's ability to cope with high flow velocities at high pressure drops, its inherent robustness and controllability is perfect for this application.